



Air-Cooled Liquid Chillers with Integrated Hydronic Module

AQUASNAP

PRO-DIALOG PLUS



Carrier is participating in the Eurovent Certification Programme. Products are as listed in the Eurovent Directory of Certified Products.



Quality Management System Approval

30RA 040-240 "B"

Nominal cooling capacity 39-245 kW

The new generation of Aquasnap liquid chillers features the latest technological innovations: Scroll compressors, low-noise fans made of a composite material, auto-adaptive microprocessor control, full optimisation for the ecological refrigerant HFC-407C. The Aquasnap includes a complete hydronic module as standard, simplifying the installation to straightforward operations like connection of the power supply and the chilled water supply and return piping. An auto-adaptive control algorithm ensures intelligent control of compressor operation in most comfort air conditioning applications, making a buffer tank unnecessary.

Features

- Integrated hydronic module eliminates the need for a field-supplied pump assembly and does not require additional space. The module incorporates all components necessary for the operation of the system: removable screen filter, water pump with high available pressure, expansion tank, water flow switch, safety valve, pressure gauges, and purge valve. A throttle valve allows adjustment of the water flow in accordance with the characteristics of the installation.

All hydraulic components are protected against frost down to -20°C.

- Aquasnap is equipped with the revolutionary second-generation Flying Bird fan. This low-noise, two-speed fan is made of composite recyclable material and employs a multi-blade design and a rotating shroud, as used in the aeronautical industry. It is exceptionally quiet, and does not generate the low-frequency noise, irritating to the human ear. At part load or low outdoor temperatures the fan automatically switches to the low speed. As an option you can program fan operation at low speed, for example during the night, for quieter operation.

To reduce the operating noise even further, the fan is not fixed to the top unit panel, but supported by an extremely rigid tower chassis. This innovative structure prevents the transmission of vibrations to the unit casing and results in a more aesthetic flat top panel.

- The scroll compressors run extremely quietly and vibration-free. They are well-known for their durability and reliability. The motor is fully cooled by suction gas and permits up to 12 starts per hour. A safety valve allows reverse rotation due to incorrect wiring, without impairing compressor operation. In addition these compressors need no maintenance. The use of two compressors per circuit (except size 30RA 040) permits a reduction of the start-up current and of the power input at part load.

- The ecological refrigerant HFC-407C has no effect on the ozone layer, and is the replacement for R-22 in air conditioning applications with small and medium capacities. It has been extensively tested by Carrier for several years and offers the same reliability and even slightly superior performances to those of R-22.
- The evaporator is a welded, stainless steel plate heat exchanger, maximising the thermodynamic properties of HFC-407C and offering considerably increased performances as well as low water-side pressure drops. From size 30RA 090 upwards the units are equipped with a twin-circuit interlaced heat exchanger for safe operation at part load. When the unit is shut down, the heat exchanger is protected against freeze-up by a trace heater.
- The refrigerant circuit is designed to be completely leak-proof - for life. All pipes and the refrigeration components are welded, the capillaries, a source of leaks in the past, have been replaced. Pressure sensors, mounted directly on the pipes, take the place of the pressure switches.

From size 30RA 090 upwards, two independent refrigerant circuits ensure partial cooling capacity in all circumstances.

- The Aquasnap is designed for year-round operation and operates without the use of accessories down to -10°C outdoor temperature. A control algorithm intelligently manages operation of the fans.
- Electrical connections are simplified, and the standard Aquasnap equipment includes a main switch, and a single entry point of the three-phase without neutral power supply to the whole unit.
- Large removable panels and the hinged door of the control box ensure perfect accessibility and permit easy access to all components. Furthermore an opening allows adjustments to be made without interrupting the operation of the chiller. For the most important maintenance operations the unit top cover is easily removed (with the fan remaining in place), and total access from above is possible.

PRO-DIALOG Plus control

PRO-DIALOG Plus is an advanced numeric control system that combines complex intelligence with great operating simplicity. PRO-DIALOG Plus constantly monitors all machine parameters and safety devices, and precisely manages the operation of compressors and fans for optimum energy efficiency. It also controls the operation of the water pump.

A powerful control system

- The PID control algorithm with permanent compensation for the difference between entering and leaving water temperature and anticipation of load variations regulates compressor operation for intelligent leaving water temperature control.
- To optimise power consumption, PRO-DIALOG Plus automatically resets the chilled water temperature set-point in accordance with the outdoor air temperature or the return water temperature or uses a second set-point (example occupied/unoccupied).
- PRO-DIALOG Plus control is auto-adaptive for full compressor protection. The system permanently optimises compressor run times according to the application characteristics (water loop inertia), preventing excessive cycling. In most comfort air conditioning applications this feature makes a buffer tank unnecessary.

Clear and easy-to-use control system

- The operator interface is clear and user-friendly: LEDs and two numeric displays ensure immediate verification of all unit operating data.
- A simple push of a button, conveniently positioned on a synoptic chiller diagram gives you immediate display of the usual parameters: temperatures, pressures, set-point, compressor run times etc.
- 10 menus offer direct access to all machine controls, including a history of possible faults, for rapid and complete chiller fault diagnosis.

Extended communications capabilities

- PRO-DIALOG Plus allows remote control and monitoring of the chiller through a wired connection: start/stop, cooling/heating mode selection, power demand limit or dual set-point and customer safety lock. The system permits remote signalling of any possible anomaly for each refrigerant circuit.
- The internal clock permits programming of:
 - chiller start/stop
 - operation at the second set-point (e.g. unoccupied room)
 - operation of the chiller with the fan at low speed to reduce the noise level.
- Master/slave control of two chillers operating in parallel with operating time equalisation.
- RS 485 serial port for remote chiller control via communications bus.

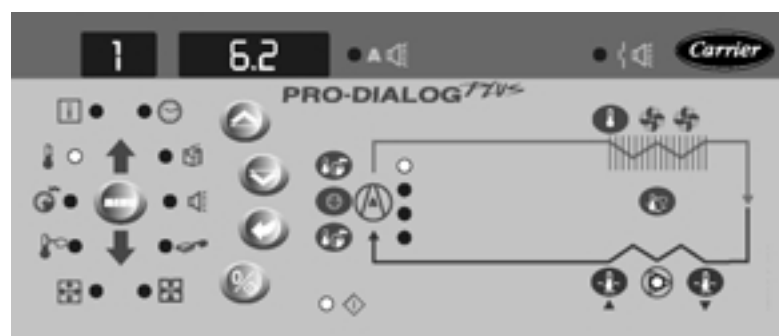

PRO-DIALOG Plus operator interface

Options and accessories

	Option	Accessory
Condenser anti-corrosion pre-treatment for marine applications	X	
Condenser post-assembly corrosion treatment for rural, urban and industrial applications	X	
Electronic compressor starter for reduction of start-up current (30RA 040-080)	X	
Operation down to -20°C outside temperature	X	
Low-temperature unit for glycol leaving temperatures from 0°C to -10°C	X	
Unit without hydronic module	X	
Hydronic module with dual pump	X	
Communications board with open JBus protocol	X	X

Sound levels

	040	050	060	070	080	090	100	120	140	160	200	240
Sound power, dB(A) 10 ⁻¹² W	82	82	82	86	87	85	85	85	89	90	91	92

According to Eurovent 8/1 (derived from ISO standard 3744 or ISO 9614-1).

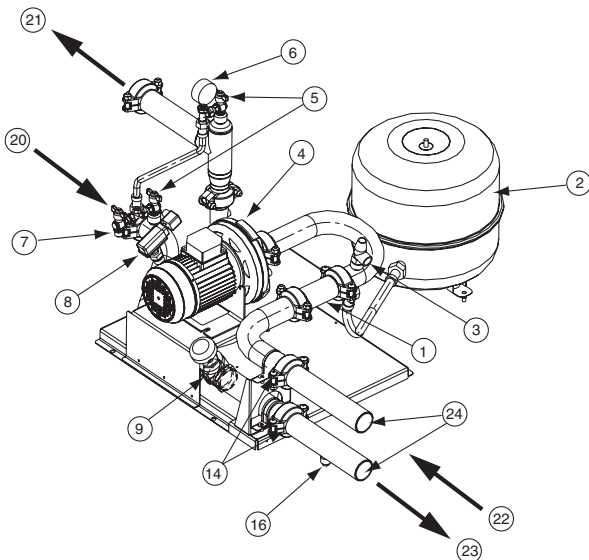

Hydronic module (040 to 160)

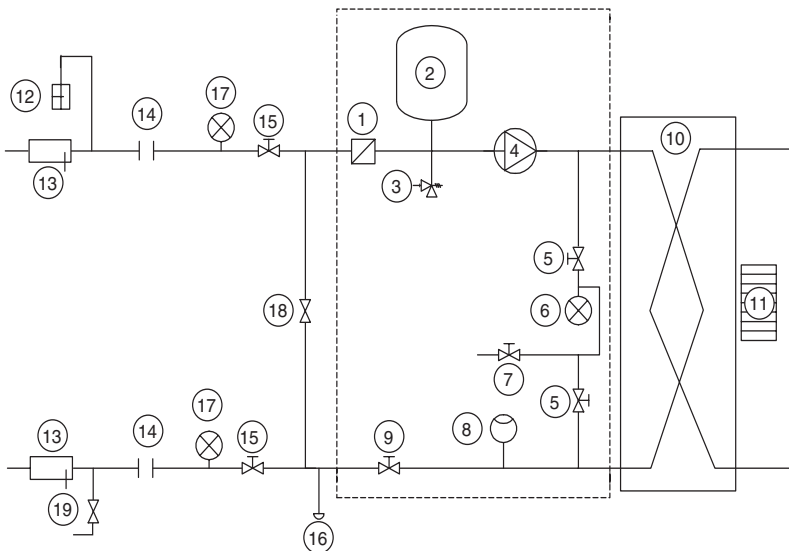

Typical hydronic circuit diagram

Legend

Components of unit and hydronic module

- 1 Victaulic screen filter
- 2 Expansion tank
- 3 Safety valve
- 4 Available pressure pump
- 5 Purge valve and pressure tap (see Installation Manual)
- 6 Pressure gauge to measure the plate heat exchanger pressure drop
(to be isolated with valve No. 5 if not used)
- 7 System air vent
- 8 Flow switch
- 9 Flow control valve
- 10 Plate heat exchanger
- 11 Evaporator defrost heater

Installation components

- 12 Air vent
- 13 Thermometer sleeve
- 14 Flexible connection
- 15 Check valve
- 16 System water drain plug (on connection pipe supplied in the unit)
- 17 Pressure gauge
- 18 Freeze-up protection bypass valve
(when valves No. 15 are closed during winter)
- 19 Charge valve
- 20 Plate heat exchanger outlet
- 21 Plate heat exchanger inlet
- 22 Water inlet
- 23 Water outlet
- 24 Customer connection sleeves for welded or screw connection
(supplied)

--- Hydronic module (units with hydronic module)

Note: Units without hydronic module (option) are equipped with a flow switch and an internal piping heater.

Physical data

30RA		040	050	060	070	080	090	100	120	140	160	200	240
Nominal cooling capacity*	kW	39.4	49.0	57.0	67.0	79.0	89.0	97.0	115.0	135.0	157.0	202.0	245.0
Operating weight with hydronic module	kg												
Single pump		526	584	597	611	631	1093	1106	1205	1212	1248	2133	2305
Dual pump		606	664	677	691	708	1170	1183	1305	1312	1348	2221	2393
Operating weight without hydronic module		502	560	573	587	605	1062	1075	1167	1174	1210	1986	2158
Refrigerant charge	kg	R-407C											
Circuit A		10	13	15	12.5	18	10	10	15	12.5	18	21	28
Circuit B		-	-	-	-	-	13	14	15	12.5	18	28	28
Compressors		Hermetic scroll compressor, 48.3 r/s											
Quantity, circuit A		1	2	2	2	2	1	1	2	2	2	2	3
Quantity, circuit B		-	-	-	-	-	2	2	2	2	2	3	3
No. of capacity steps		1	2	2	2	2	3	3	4	4	4	5	6
Minimum capacity	%	100	46	42	50	50	25	25	21	25	25	20	16.6
Control type		PRO-DIALOG Plus											
Condensers		Grooved copper tubes, aluminium fins											
Fans		Axial Flying Bird fans with rotating shroud											
Quantity		1	1	1	1	1	2	2	2	2	2	4	4
Total air flow (high speed)	l/s	3945	3780	4220	5150	5800	7725	8165	8840	10300	11600	17343	20908
Speed (high/low speed)	r/s	11.5/5.8	11.5/5.8	11.5/5.8	15.6/7.8	15.6/7.8	11.5/5.8	11.5/5.8	11.5/5.8	15.6/7.8	15.6/7.8	11.5/5.8	15.6/7.8
Evaporator		Direct-expansion welded plate heat exchanger											
Water volume	l	3.6	4.6	5.9	6.5	7.6	7.2	8.2	9.8	11.4	13.0	22.0	26.0
Max. water-side operating pressure	kPa												
Option without hydronic module		1000	1000	1000	1000	1000	1000	1000	1000	1000	1000	1000	1000
Unit with hydronic module		300	300	300	300	300	300	300	300	300	300	400	400
Hydronic module		Monocell composite pump											
Pump (single centrifugal, 48.3 r/s)													Monocell pump
Quantity		1	1	1	1	1	1	1	1	1	1	1	1
Expansion tank volume	l	12	12	12	12	12	35	35	35	35	35	50	50
Expansion tank pressure	kPa	100	100	100	100	100	150	150	150	150	150	150	150
Water connections (with and without hydronic module)		Victaulic (connection sleeves supplied)											
Diameter	in	2	2	2	2	2	2	2	2-1/2	2-1/2	2-1/2	3	3
Outside tube diameter	mm	60.3	60.3	60.3	60.3	60.3	60.3	60.3	76.1	76.1	76.1	88.9	88.9

* Nominal conditions: evaporator entering/leaving water temperature 12°C/7°C, outdoor air temperature 35°C.

Electrical data

30RA (without hydronic module)		040	050	060	070	080	090	100	120	140	160	200	240
Power circuit													
Nominal power supply	V-ph-Hz	400-3-50											
Voltage range	V	360-440											
Control circuit supply		The control circuit is supplied via the unit-mounted transformer											
Maximum unit power input*	kW	20.3	24.6	30.1	35.2	39.9	44.1	49.6	60.5	70.6	79.6	104.2	124.9
Nominal unit current draw**	A	27.9	34.7	41.1	47.0	54.3	62.7	69.1	82.3	94.1	108.6	140.2	168.7
Maximum unit current draw at 360 V***	A	36.9	45.6	54.9	62.7	72.4	82.6	91.9	109.8	125.4	144.8	185.4	222.9
Maximum unit current draw at 400 V****	A	33.6	41.4	49.7	56.9	65.6	75.1	83.4	99.5	113.9	131.3	168.6	202.8
Maximum start-up current													
Standard unit†	A	158.4	151.0	168.9	176.1	190.4	199.8	208.1	218.6	233.0	256.1	293.4	327.6
With electronic starter control‡	A	99.0	101.0	113.0	120.0	128.0	-	-	-	-	-	-	-
Holding current for three-phase short circuits		kA	6	6	6	6	6	10	10	10	10	10	19

- * Power input of the compressor(s) + fan(s) at maximum unit operating conditions: entering/leaving water temperature = 15°C/10°C, maximum condensing temperature of 67.8°C and 400 V nominal voltage (values given on the unit name plate).
- ** Nominal unit current draw at the following conditions: evaporator entering/leaving water temperature 12°C/7°C, outdoor air temperature 35°C. The current values are given at 400 V nominal voltage (values given on the unit name plate).
- *** Maximum unit operating current at maximum unit power input and 360 V.
- **** Maximum unit operating current at maximum unit power input and 400 V (values given on the unit name plate).
- † Maximum instantaneous starting current at 400 V nominal voltage and with compressor in across-the-line start (maximum operating current of the smallest compressors + fan current + locked rotor current of the largest compressor).
- ‡ Maximum instantaneous starting current at 400 V nominal voltage and with compressor with electronic starter (maximum operating current of the smallest compressor(s) + fan current + reduced start-up current of the largest compressor).

Hydronic module		040	050	060	070	080	090	100	120	140	160	200	240
Single pump													
Shaft power	kW	0.75	0.75	0.75	0.75	1.1	1.1	1.1	1.85	1.85	1.85	5.5	5.5
Power input*	kW	1.1	1.1	1.1	1.1	1.4	1.4	1.4	2.5	2.5	2.5	6.6	6.6
Maximum current draw at 400 V**	A	2.1	2.1	2.1	2.1	3.1	3.1	3.1	5	5	5	10.9	10.9
Dual pump													
Shaft power	kW	2.2	2.2	2.2	2.2	2.2	2.2	2.2	3	3	3	5.5	5.5
Power input*	kW	2.7	2.7	2.7	2.7	2.7	2.7	2.7	4	4	4	6.6	6.6
Maximum current draw at 400 V**	A	4.7	4.7	4.7	4.7	4.7	4.7	4.7	6.6	6.6	6.6	10.9	10.9

- Note: The water pump power input values are given for guidance only.
- * To obtain the maximum power input for a unit with hydronic module add the maximum unit power input from the top table to the pump power input (*) from the table above.
- ** To obtain the maximum unit operating current draw for a unit with hydronic module add the maximum unit current draw from the top table to the pump current draw from the table above.

Electrical data notes:

- 30RA 040-240 units have a single power connection point located at the main switch.
 - The control box includes the following standard features:**
 - a main disconnect switch, starter and motor protection devices for each compressor, the fan, the optional pumps
 - the control devices
 - Field connections:**

All connections to the system and the electrical installations must be in full accordance with all applicable local codes.
 - The Carrier 30RA units are designed and built to ensure conformance with these codes. The recommendations of European standard EN 60204-1 (machine safety - electrical machine components - part 1: general regulations - corresponds to IEC 60204-1) are specifically taken into account, when designing the electrical equipment.
- Notes:**
- Generally the recommendations of IEC 60364 are accepted as compliance with the requirements of the installation directives. Conformance with EN 60204-1 is the best means of ensuring compliance with the Machines Directive § 1.5.1.
 - Annex B of EN 60204-1 describes the electrical characteristics used for the operation of the machines.
- The operating environment for the 30RA units is specified below:
 - Environment* - Environment as classified in EN 60721 (corresponds to IEC 60721):
 - outdoor installation*
 - ambient temperature range: -10°C to +45°C ± 1K, class 4K3*
 - altitude: ≤ 2000 m
 - presence of hard solids, class 4S2 (no significant dust present)
 - presence of corrosive and polluting substances, class 4C2 (negligible)
 - vibration and shock, class 4M2
 - Competence of personnel, class BA4* (trained personnel - IEC 60364)
 - Power supply frequency variation: ± 2 Hz.
 - The neutral (N) conductor must not be connected directly to the unit (if necessary use transformers)
 - Over-current protection of the power supply conductors is not provided with the unit.
 - The factory-installed disconnect switches/circuit breakers are of a type that is suitable to interrupt the power in accordance with EN60947-3 (corresponds to IEC 60947-3).
 - The units are designed for connection to TN networks (IEC 60364). For IT networks the earth connection must not be at the network earth. Provide a local earth, consult competent local organisations to complete the electrical installation.

NOTE: If particular aspects of an actual installation do not conform to the conditions described above, or if there are other conditions which should be considered, always contact your local Carrier representative.

* The required protection level for this class is IP43BW (according to reference document IEC 60529). All 30RA units are protected to IP44CW and fulfil this protection condition.

Operating limits

30RA	Evaporator water flow rate, l/s			Max. water flow**
	Min. water flow	Max. water flow*		
		Single pump	Dual pump	
040	1.1	3.5	4.4	3.7
050	1.1	4	5.2	4.6
060	1.4	4.4	6	5.8
070	1.5	4.6	6.4	6.4
080	1.7	5.5	6.8	7.3
090	2.7	5.6	6.9	7.6
100	3	5.8	7.4	8.8
120	3.6	8.5	10.5	10.8
140	4.2	8.8	11.4	12.7
160	4.8	9.1	11.9	14.4
200	5.6	15.3	15.3	19.1
240	6.8	23.4	23.4	24.2

30RA	Entering water temperature at start-up, °C		Entering water temperature at shut-down, °C
	Minimum †, °C	Maximum °C	Maximum °C
040 - 240	7.8	30	55

30RA	Leaving water temperature during operation, °C		Entering air temperature, °C	
	Minimum ‡, °C	Maximum °C	Minimum °C	Maximum °C
040 - 240	5	15	-10	46

Notes:

- * Maximum flow rate for an available pressure of 50 kPa (unit with hydronic module)
- ** Maximum flow rate for a pressure drop of 100 kPa (unit without hydronic module)
- † For applications requiring operation below 7.8°C contact Carrier.
- ‡ For applications requiring operation below 5°C anti-freeze must be used.

Operating range



Notes:

1. Evaporator $\Delta t = 5$ K
2. The evaporator and the hydronic circuit pump are protected against frost down to -20°C.

■ Operating range with required anti-freeze solution and special Pro-Dialog control configuration

Available static system pressure

Single pump



Dual pump

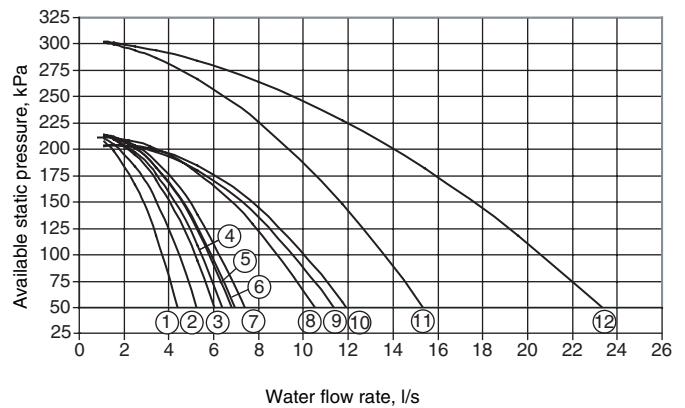

Legend

- | | |
|----------------|-------------|
| 1 30RA 040 | 7 30RA 120 |
| 2 30RA 050 | 8 30RA 140 |
| 3 30RA 060 | 9 30RA 160 |
| 4 30RA 070 | 10 30RA 200 |
| 5 30RA 080-090 | 11 30RA 240 |
| 6 30RA 100 | |

Legend

- | | |
|------------|-------------|
| 1 30RA 040 | 7 30RA 100 |
| 2 30RA 050 | 8 30RA 120 |
| 3 30RA 060 | 9 30RA 140 |
| 4 30RA 070 | 10 30RA 160 |
| 5 30RA 080 | 11 30RA 200 |
| 6 30RA 090 | 12 30RA 240 |

Water loop volume

Minimum water loop volume

Volume = CAP (kW) x N* = litres, where CAP is the nominal cooling capacity at nominal operating conditions.

Air conditioning application	N*
30RA 040	3.5
30RA 050 to 240	2.5
Industrial process cooling	
30RA 040 to 240	See note

NOTE:
For industrial process cooling applications, where high stability of the water temperature levels must be achieved, the values above must be increased.

Maximum water loop volume

Units with hydronic module incorporate an expansion tank that limits the water loop volume. The table below gives the maximum loop volume for pure water or ethylene glycol with various concentrations.

	30 RA 040-080 (in litres)	30 RA 090-160 (in litres)	30 RA 200-240 (in litres)
Pure water	600	1500	2000
10% ethylene glycol	450	1200	1600
20% ethylene glycol	400	1000	1400
35% ethylene glycol	300	800	1000

Dimensions/clearances

30RA 040-080

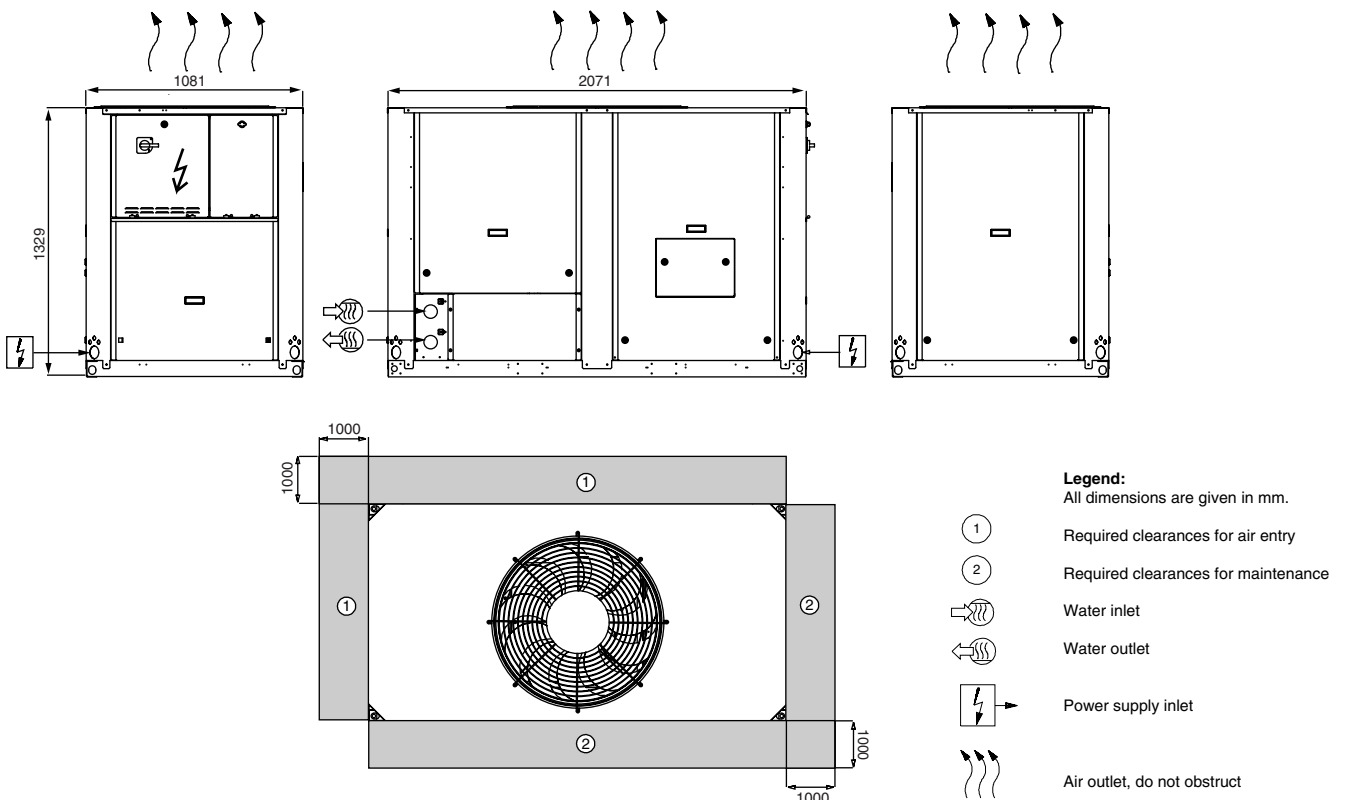

- Legend:**
All dimensions are given in mm.
- ① Required clearances for air entry
 - ② Required clearances for maintenance
 - Water inlet
 - Water outlet
 - Power supply inlet
 - Air outlet, do not obstruct

NOTE:
Drawings are not contractually binding. Before designing an installation, consult the certified dimensional drawings, available on request.

Dimensions/clearances

30RA 090-160

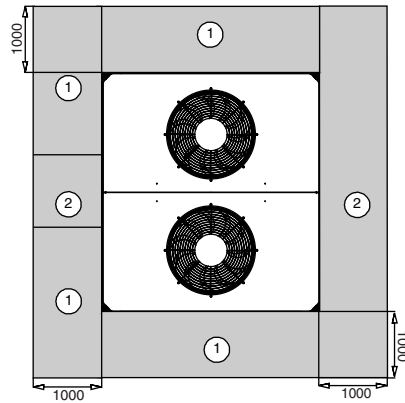
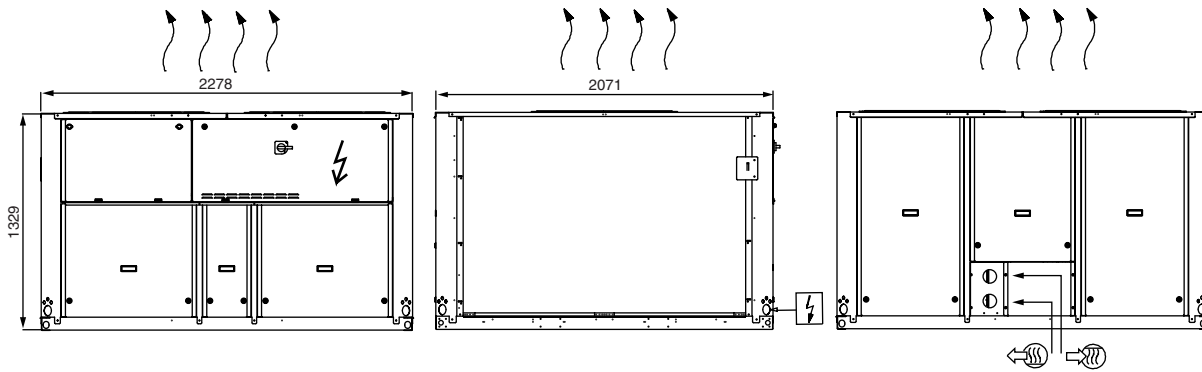

30RA 200-240

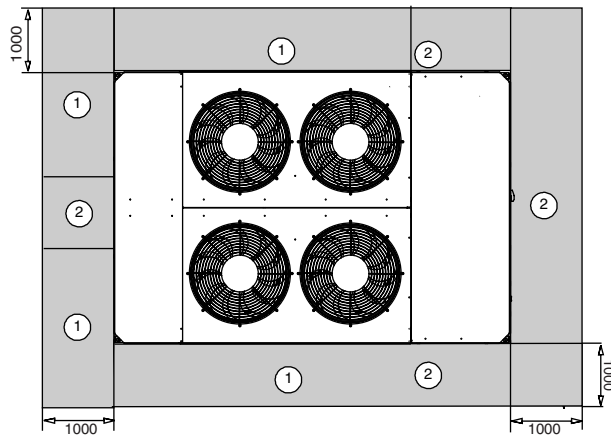
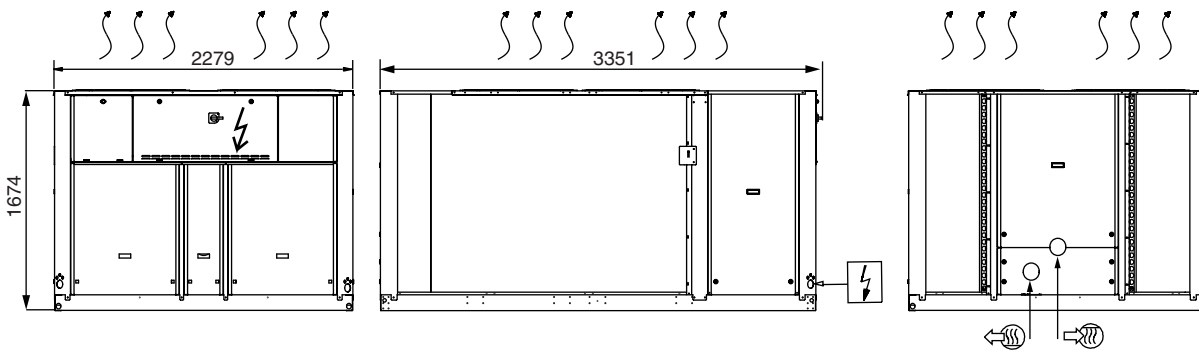

Legend:

All dimensions are given in mm.

- ① Required clearances for air entry
- ② Required clearances for maintenance
- Water inlet
- Water outlet
- Power supply inlet
- Air outlet, do not obstruct

NOTE:

Drawings are not contractually binding. Before designing an installation, consult the certified dimensional drawings, available on request.

30RA Condenser entering air temperature, °C

	LWT °C	25						30						35						40						45										
		CAP	COMP	UNIT	COOL	COOL	PRES	PRES	CAP	COMP	UNIT	COOL	COOL	PRES	PRES	CAP	COMP	UNIT	COOL	COOL	PRES	PRES	CAP	COMP	UNIT	COOL	COOL	PRES	PRES	CAP	COMP	UNIT	COOL	COOL	PRES	PRES
		kW	kW	kW	l/s	kPa	kPa	kPa	kW	kW	kW	l/s	kPa	kPa	kPa	kW	kW	kW	l/s	kPa	kPa	kPa	kW	kW	kW	l/s	kPa	kPa	kPa	kW	kW	kW	l/s	kPa	kPa	kPa
040	5	41.1	11.4	12.6	1.96	32	138	187	39	12.5	13.7	1.86	28	141	190	36.9	13.8	15	1.76	25	145	193	34.9	15.1	16.3	1.67	23	148	195	32.9	16.6	17.8	1.57	20	151	198
050		51	14.2	15.4	2.46	31	132	185	48.7	15.7	16.9	2.33	28	137	188	46	17.3	18.5	2.2	25	141	192	43.3	19	20.2	2.07	22	145	195	40.6	20.8	22	1.94	19	149	198
060		61	17.3	18.5	2.89	27	128	185	57	19	20.2	2.73	24	133	189	54	20.8	22	2.57	21	139	193	51	22.7	23.9	2.42	19	143	196	47.3	24.8	26	2.26	17	148	199
070		70	20.4	22.9	3.34	30	115	179	66	22.2	24.7	3.16	27	122	183	63	24.2	26.7	2.99	24	128	187	59	26.4	28.9	2.82	21	134	191	56	28.7	31.2	2.66	19	140	195
080		83	23.6	26.1	3.96	33	138	169	79	26	28.5	3.76	30	147	174	74	28.5	31	3.55	26	156	180	70	31.1	33.6	3.35	23	164	185	66	34	36.5	3.14	21	171	189
090		94	24.9	27.3	4.47	40	114	154	89	27.5	29.9	4.24	37	126	161	84	30.2	32.6	4	33	136	168	79	33.2	35.6	3.78	30	146	174	74	36.3	38.7	3.55	26	156	180
100		102	28.5	30.9	4.88	36	103	150	97	31.3	33.7	4.62	33	116	158	91	34.3	36.7	4.36	29	128	166	86	37.6	40	4.11	26	139	172	81	41.1	43.5	3.86	23	150	179
120		121	34.5	36.9	5.78	34	160	166	114	37.9	40.3	5.46	31	169	171	108	41.5	43.9	5.15	28	178	176	101	45.4	47.8	4.83	25	186	180	95	49.6	52	4.52	22	194	184
140		141	40.3	45.3	6.74	34	137	160	134	44	49	6.39	31	149	165	127	47.9	53	6.05	28	160	170	119	52	57	5.7	25	170	175	112	57	62	5.36	22	179	179
160		166	47.3	52	7.93	37	100	146	157	52	57	7.52	33	116	154	149	57	62	7.11	30	131	160	140	62	67	6.69	27	145	167	131	68	73	6.28	24	158	172
200		210	57	64	10.1	32	187	187	199	62	70	9.53	29	197	197	189	68	76	9.01	26	208	208	178	74	82	8.5	23	217	217	167	81	88	7.99	21	226	226
240		256	68	78	12.2	30	225	225	242	74	84	11.6	27	232	232	229	81	91	11	24	238	238	216	88	98	10.3	22	244	244	203	96	106	9.71	19	250	250
040	6	42.4	11.6	12.8	2.03	34	135	184	40.3	12.7	13.9	1.92	30	139	188	38.1	13.9	15.1	1.82	27	143	191	36.1	15.3	16.5	1.72	24	146	194	34	16.7	17.9	1.63	22	149	196
050		53	14.4	15.6	2.54	33	129	183	50	15.9	17.1	2.4	30	134	187	47.5	17.5	18.7	2.27	26	139	190	44.7	19.2	20.4	2.14	24	143	193	42	21	22.2	2.01	21	147	196
060		62	17.5	18.7	2.99	29	124	183	59	19.2	20.4	2.82	26	130	187	56	21	22.2	2.66	23	136	191	52	23	24.2	2.5	20	141	194	48.9	25.1	26.3	2.34	18	146	198
070		72	20.6	23.1	3.44	32	110	176	68	22.5	25	3.27	29	118	181	65	24.5	27	3.09	26	125	185	61	26.7	29.2	2.92	23	131	189	57	29.1	31.6	2.75	20	137	193
080		85	24	26.5	4.08	35	132	165	81	26.3	28.8	3.87	31	142	171	77	28.8	31.3	3.66	28	151	177	72	31.5	34	3.45	25	160	182	68	34.3	36.8	3.23	22	168	187
090		97	25.2	27.6	4.61	43	107	149	92	27.8	30.2	4.37	39	119	157	87	30.6	33	4.14	35	130	164	82	33.6	36	3.9	31	141	171	77	36.8	39.2	3.67	28	151	177
100		106	28.9	31.3	5.04	39	95	145	100	31.7	34.1	4.77	35	109	154	94	34.8	37.2	4.51	31	121	162	89	38.1	40.5	4.25	28	133	169	83	41.6	44	3.99	25	144	175
120		125	35	37.4	5.97	36	154	163	118	38.4	40.8	5.64	33	164	168	111	42.1	44.5	5.32	29	173	173	105	46	48.4	5	26	182	178	98	50	53	4.68	23	190	182
140		145	40.9	45.9	6.95	36	130	156	138	44.5	49.5	6.59	33	142	162	131	48.5	54	6.24	30	154	167	123	53	58	5.89	27	164	172	116	58	63	5.55	24	174	177
160		171	47.9	53	8.16	39	91	142	162	53	58	7.74	35	108	150	153	58	63	7.32	32	124	157	144	63	68	6.89	28	138	164	135	69	74	6.47	25	152	170
200		218	58	65	10.4	34	179	179	206	63	71	9.86	31	191	191	195	69	76	9.33	28	201	201	184	75	83	8.8	25	212	212	173	82	89	8.27	22	221	221
240		264	69	79	12.6	32	220	220	251	75	86	12	29	227	227	237	82	92	11.3	26	234	234	224	89	100	10.7	23	241	241	210	97	107	10.1	21	247	247
040	7	43.7	11.7	12.9	2.09	36	132	182	41.5	12.9	14.1	1.98	32	137	186	39.4	14.1	15.3	1.88	29	141	189	37.2	15.5	16.7	1.78	26	144	192	35.2	16.9	18.1	1.68	23	148	195
050		55	14.6	15.8	2.61	35	126	180	52	16.1	17.3	2.48	32	131	184	49	17.7	18.9	2.34	28	136	188	46.2	19.4	20.6	2.21	25	141	192	43.4	21.3	22.5	2.07	22	145	195
060		64	17.8	19	3.08	31	120	180	61	19.5	20.7	2.91	28	127	185	57	21.3	22.5	2.74	24	133	189	54	23.3	24.5	2.58	22	139	193	51	25.4	26.6	2.42	19	143	196
070		74	20.9	23.4	3.55	34	106	173	70	22.8	25.3	3.37	30	114	178	67	24.8	27.3	3.19	27	121	183	63	27	29.5	3.01	24	128	187	59	29.4	31.9	2.83	21	134	191
080		88	24.3	26.8	4.19	37	127	162	83	26.6	29.1	3.98	33	137	168	79	29.2	31.7	3.76	30	147	174	74	31.9	34.4	3.55	26	156	180	70	34.7	37.2	3.33	23	164	185
090		100	25.6	28	4.75	45	100	145	94	28.2	30.6	4.51	41	112	153	89	31	33.4	4.27	37	124	160	84	34	36.4	4.03	33	135	167	79	37.2	39.6	3.79	30	146	174
100		109	29.3	31.7	5.2	41	86	140	103	32.1	34.5	4.92	37	101	149	97	35.2	37.6	4.65	33	114	157	92	38.5	40.9	4.38	30	127	165	86	42.1	44.5	4.12	27	139	172
120		129	35.5	37.9	6.16	39	147	160	122	38.9	41.3	5.82	35	158	165	115	42.6	45	5.49	31	168	171	108	46.6	49	5.16	28	178	175	101	51	53	4.83	25	186	180
140		150	41.4	46.4	7.16	38	122	152	142	45.1	50	6.8	35	135	159	135	49.2	54	6.44	31	147	164	127	54	59	6.08	28	159	170	120	58	63	5.73	25	169	175
160		175	48.6	54	8.38	41	81	138	167	53	58	7.96	37	99	146	157	58	63	7.53	33	116	153	148	64	69	7.09	30	131	160	139	69	74	6.66	27	146	167
200		225	59	66	10.8	37	171	171	214	64	72	10.2	33	184	184	202	70	77	9.65	30	195	195	190	76	84	9.1	27	206	206	179	83	90	8.55	24	216	216
240		273	70	80	13.1	34	215	215	259	77	87	12.4	31	223	223	245	83	93	11.7	28	230	230	231	91	101	11.1	25	237	237	217	98	108	10.4	22	244	244

Legend:

- LWT Leaving water temperature
- CAP kW Net cooling capacity
- COMP kW Compressor power input
- UNIT kW Unit power input (compressors, fans, control circuit)
- COOL l/s Evaporator water flow rate
- COOL kPa Evaporator pressure drop
- PRES kPa (1) Available pressure at the unit outlet (unit with single-pump hydronic module)
- PRES kPa (2) Available pressure at the unit outlet (unit with dual-pump hydronic module)

Full load correction factors for Eurovent laboratory test:

- Net cooling capacity 1.000
- Energy efficiency ratio 1.000
- Evaporator pressure drop 1.000

Application data:

- Standard units
- Refrigerant: R-407C
- Evaporator temperature rise: 5 K
- Evaporator fluid: chilled water
- Fouling factor: 0.44 x 10⁻⁴ (m² K)/W

Performances in accordance with EN 12055.

30RA Condenser entering air temperature, °C																																				
LWT	25							30							35							40							45							
	CAP	COMP	UNIT	COOL	COOL	PRES	PRES	CAP	COMP	UNIT	COOL	COOL	PRES	PRES	CAP	COMP	UNIT	COOL	COOL	PRES	PRES	CAP	COMP	UNIT	COOL	COOL	PRES	PRES	CAP	COMP	UNIT	COOL	COOL	PRES	PRES	
°C	kW	kW	kW	l/s	kPa	(1) kPa	(2) kPa	kW	kW	kW	l/s	kPa	(1) kPa	(2) kPa	kW	kW	kW	l/s	kPa	(1) kPa	(2) kPa	kW	kW	kW	l/s	kPa	(1) kPa	(2) kPa	kW	kW	kW	l/s	kPa	(1) kPa	(2) kPa	
040	8	45.1	11.8	13	2.15	38	130	180	42.8	13	14.2	2.05	34	134	184	40.6	14.3	15.5	1.94	31	139	187	38.4	15.6	16.8	1.84	28	142	191	36.3	17.1	18.3	1.73	25	146	194
050		56	14.8	16	2.69	37	122	178	53	16.3	17.5	2.55	33	128	182	50	17.9	19.1	2.41	30	134	186	47.6	19.7	20.9	2.27	26	139	190	44.7	21.5	22.7	2.14	24	143	193
060		66	18	19.2	3.17	33	116	178	63	19.7	20.9	3	29	123	183	59	21.6	22.8	2.83	26	130	187	56	23.6	24.8	2.66	23	136	191	52	25.7	26.9	2.49	20	141	195
070		76	21.2	23.7	3.65	36	101	170	73	23.1	25.6	3.47	32	109	175	69	25.1	27.6	3.28	29	117	180	65	27.4	29.9	3.1	26	124	185	61	29.7	32.2	2.92	23	131	189
080		90	24.6	27.1	4.31	39	121	158	86	27	29.5	4.09	35	132	165	81	29.5	32	3.87	31	142	171	76	32.2	34.7	3.65	28	152	177	72	35.1	37.6	3.43	25	160	183
090		102	25.9	28.3	4.9	48	92	140	97	28.5	30.9	4.65	43	105	148	92	31.3	33.7	4.4	39	118	156	87	34.4	36.8	4.16	35	130	164	82	37.6	40	3.91	32	140	170
100		112	29.7	32.1	5.36	43	78	135	106	32.5	34.9	5.08	39	93	144	100	35.6	38	4.8	35	107	153	95	39	41.4	4.52	32	121	161	89	42.5	44.9	4.25	28	133	169
120		133	36	38.4	6.34	41	141	157	126	39.5	41.9	6	37	153	163	118	43.2	45.6	5.66	33	163	168	111	47.1	49.5	5.32	29	173	173	104	51	54	4.99	26	182	178
140		154	42	47	7.37	40	114	149	147	45.7	51	7	37	128	155	139	49.8	55	6.63	33	141	161	131	54	59	6.27	30	153	167	124	59	64	5.91	27	164	172
160		180	49.2	54	8.61	43	71	133	171	54	59	8.17	39	90	142	162	59	64	7.73	35	108	150	153	64	69	7.29	32	124	157	143	70	75	6.85	28	140	164
200		233	59	67	11.1	39	163	163	221	65	72	10.5	35	176	176	209	71	78	9.97	32	188	188	197	77	85	9.4	28	200	200	185	84	91	8.83	25	211	211
240		282	71	81	13.5	36	210	210	268	78	88	12.8	32	218	218	253	84	95	12.1	29	226	226	239	92	102	11.4	26	233	233	225	100	110	10.7	23	240	240
040	10	47.7	12.1	13.3	2.28	43	124	175	45.4	13.3	14.5	2.17	39	129	179	43	14.6	15.8	2.06	35	134	183	40.8	16	17.2	1.95	31	138	187	38.5	17.5	18.7	1.84	28	142	190
050		60	15.1	16.3	2.84	41	116	173	56	16.7	17.9	2.7	37	122	178	53	18.3	19.5	2.55	33	128	182	50	20.1	21.3	2.41	30	134	186	47.5	22	23.2	2.27	26	139	190
060		70	18.5	19.7	3.36	37	108	172	67	20.2	21.4	3.18	33	116	178	63	22.1	23.3	3	29	123	183	59	24.1	25.3	2.82	26	130	187	55	26.3	27.5	2.65	23	136	191
070		81	21.8	24.3	3.86	40	91	163	77	23.7	26.2	3.67	36	100	169	73	25.8	28.3	3.48	32	109	175	69	28	30.5	3.29	29	117	180	65	30.4	32.9	3.1	26	124	185
080		95	25.3	27.8	4.53	43	110	151	90	27.7	30.2	4.31	39	121	158	85	30.2	32.7	4.08	35	133	165	81	33	35.5	3.85	31	143	172							
090		108	26.5	28.9	5.18	53	76	129	103	29.2	31.6	4.92	48	91	139	98	32.1	34.5	4.66	44	104	148	92	35.1	37.5	4.41	39	117	156	87	38.4	40.8	4.16	35	130	164
100		119	30.4	32.8	5.67	48	60	123	113	33.4	35.8	5.38	44	76	134	106	36.5	38.9	5.09	39	92	144	100	39.9	42.3	4.8	35	107	153	95	43.5	45.9	4.52	31	121	161
120		141	37	39.4	6.72	45	128	150	133	40.5	42.9	6.36	41	141	156	126	44.2	46.6	6	37	153	163	118	48.3	51	5.65	33	164	168	111	53	55	5.3	29	174	173
140		163	43.1	48.1	7.8	45	97	141	155	46.9	52	7.41	41	113	148	147	51	56	7.03	37	127	155	139	55	60	6.65	33	141	161	131	60	65	6.27	30	153	167
160		190	51	56	9.07	47	50	124	180	55	60	8.61	43	71	133	171	60	65	8.15	39	91	142	161	66	71	7.7	35	109	150							
200		247	61	69	11.8	44	147	147	235	67	74	11.2	40	161	161	222	73	80	10.6	36	175	175	209	79	87	10	32	188	188	197	86	93	9.39	28	200	200
240		300	74	84	14.3	40	200	200	285	80	90	13.6	36	209	209	269	87	97	12.9	33	217	217	254	94	104	12.1	29	226	226	239	102	112	11.4	26	234	234

Legend:

- LWT Leaving water temperature
- CAP kW Net cooling capacity
- COMP kW Compressor power input
- UNIT kW Unit power input (compressors, fans and control circuit)
- COOL l/s Evaporator water flow rate
- COOL kPa Evaporator pressure drop
- PRES kPa(1) Available pressure at the unit outlet (unit with single-pump hydronic module)
- PRES kPa(2) Available pressure at the unit outlet (unit with dual-pump hydronic module)

Full load correction factors for Eurovent laboratory test:

- Net cooling capacity 1.000
- Energy efficiency ratio 1.000
- Evaporator pressure drop 1.000

Application data:

- Standard units
- Refrigerant: R-407C
- Evaporator temperature rise: 5 K
- Evaporator fluid: chilled water
- Fouling factor: 0.44 x 10⁻⁴ (m² K)/W

Performances in accordance with EN 12055.

Guide specifications

Air-cooled liquid chillers
Nominal cooling capacity 39 to 245 kW
Carrier model: 30RA

Part 1 - General

System description

- **Air-cooled liquid chiller for outdoor installation, equipped with scroll compressors, low-noise fans, auto-adaptive microprocessor control and operating with HFC-407C refrigerant which has no effect on the ozone layer.**

Quality assurance

- 30RA units comply with requirements of European directives:
 - machinery directive 98/37/EC, modified,
 - low voltage directive 73/23/EEC, modified.
 - electromagnetic compatibility directive 89/336/EEC, modifiedand with the applicable recommendations of European standards:
 - machine safety, electrical equipment in machines, general regulations: EN 60204-1,
 - radiated electromagnetic emissions: EN 50081-1,
 - conducted electromagnetic emissions: EN 50081-2,
 - electromagnetic immunity EN 50082-2.30RA units have been designed and tested in a facility with a quality assurance system certified ISO 9001. 30RA units have been assembled in a facility with an environment management system certified ISO 14001. The published performances have been certified by Eurovent and verified by independent laboratories. All units undergo a run test before shipment.

Part 2 - Products

Equipment

Compressor

- Hermetic scroll compressor with only three moving parts, 2-pole electric motor, cooled by suction gas with overload protection through an internal thermostat and/or thermal relay. Oil level sight glass and polyolester synthetic oil charge.

Water heat exchanger

- Stainless steel plate heat exchanger with welded copper connections; from size 30RA 090 onwards the water heat exchanger has two interlaced independent refrigerant circuits.
- Closed-cell thermal foam insulation. Anti-freeze protection during operation by flow switch (standard on all versions) and during shutdown down to -20°C by electric resistance heater.

Air heat exchanger/fan

- One (30RA 040-080) or two (30RA 090-240) vertical coils with slotted aluminium fins expanded into grooved copper tubes. Coil protection grille made of steel wire, coated in polyethylene.
- Low-noise axial Carrier Flying Bird fan with 11 blades and a rotating shroud, made of a composite material. Three-phase, two-speed motor (11.5/5.8 r/s or 15.6/7.8 r/s), insulation class F, protection category IP 55, overload protection by thermal relay. Vertical air flow with protection grille made of steel wire, coated in polyethylene.

Refrigerant circuit

- Each circuit includes: liquid line valve, moisture sight glass, thermostatic expansion device, pressure and temperature sensors, safety valve, manually reset high pressure switch, and a refrigerant charge of HFC-407C. All components of the refrigerant circuit are welded for total and lasting leak-tightness.

Control and power circuit control box

- The control box is accessible via a hinged door. It includes a main disconnect switch, fuses and circuit breakers, compressor, fan and water pump contactors, thermal relays, low-voltage control circuit transformer (24 V control circuit) and the Pro-Dialog control system.

The whole unit is supplied by a single power connection point (three-phase supply without neutral).

Chassis/cabinet

- Chassis and cabinet made of galvanised sheet steel. Painted in oven-baked polyester powder paint in light grey colour (RAL 7035). Removable panels with 1/4 turn locks.

Hydronic module

- Hydronic module, integrated into the chiller, including: removable screen filter, expansion tank, single monocell centrifugal water pump (dual water pump optional) - three-phase motor with internal thermal protection, water flow switch, safety valve, set to 3 bar, flow control valve, pressure gauge and purges. Internal piping made of galvanised steel. Customer-side Victaulic connections with welding or screw connection sleeves. Protection against ice build-up down to -20°C by thermal insulation and water pump cycling.

Note: Units without hydronic module (option): internal water piping protected against frost down to -10°C by electric resistance heater.

Carrier Pro-Dialog Plus control system

Pro-Dialog Plus ensures the following functions:

Control

- Entering or leaving water temperature control by PID loop with compressor run time equalising. The system permanently adjusts the system inertia and ensures complete prevention of excessive compressor cycling. The chiller can safely operate with a low system water volume which often makes the use of a buffer tank unnecessary (see minimum water volume in this document).
- Head pressure control by auto-adaptive algorithm (fan speed).
- Water pump control (optional dual pump with automatic change-over).
- Control at the second set point (example: unoccupied room).
Set point reset as a function of the air temperature or the difference between entering/leaving water temperature.

Safety

- The system checks the evolution of the parameters (temperatures, pressures etc.), and responds to maintain the compressor within the operating range. If despite this one parameter exceeds its limit, an alert message is generated or the unit is shut down. The following faults cause the refrigerant circuit or the unit to be shut down:
 - Low suction pressure
 - High discharge pressure
 - Low suction temperature
 - Compressor, water pump overload
 - Reverse compressor rotation
 - Temperature sensor and pressure transducer fault
 - Board and loss of communication fault
 - Customer safety device tripping
 - Heat exchanger anti-freeze protection
 - More than 50 alert or fault codes to facilitate fault detection

Operator interface

- Includes status or fault LEDs, two numerical displays, a refrigerant system synoptic diagram and a command keyboard.
- Immediate display of parameters: entering/leaving water and ambient air temperatures, set point, operating temperatures and number of compressor start-ups.
- Diagnosis and complete parameter set by selection of one of the following menus: information, temperatures, pressures, set points, input values, test, configuration, alarms, alarm history and operating log.

Remote management of the chiller

- Volt-free contact inputs permit:
 - Start/stop control
 - Selection of cooling or heating mode (boiler start-up)
 - Integration of a customer safety device
 - Operation at the second set point* (example room unoccupied)
 - Maximum demand limit* (three limit levels from size 30RA 090 onwards)

* *One or the other for 30RA 040-080*
- Outputs are available for:
 - Start-up of a boiler (shutdown of the chiller)
 - Signalling of a fault condition for each circuit.
- The internal clock permits programming of the following operations:
 - chiller start/stop
 - control at the second set point (e.g. unoccupied room)
 - fan at low speed to reduce the noise level (e.g. during the night)
- Master/slave control of two chillers operating in parallel with operating time equalisation.
- RS 485 serial port for remote chiller control via communications bus.



Environmental Management System Approval



Order No. 13420-20, 09.2003. Supersedes order No. 13420-20, 11.2001.
Manufacturer reserves the right to change any product specifications without notice.
The cover photo is solely for illustration purposes, and is not contractually binding.

Manufactured by Carrier SA, Montluel, France.
Printed on Totally Chlorine Free Paper.
Printed in the Netherlands.